

FILE COPY
JLH

Ser # 24353

J. L. Ackentach

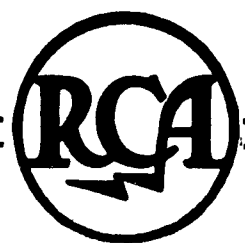

Junior VoltOhmyst

Type No. 165-A



RADIO CORPORATION OF AMERICA
Camden, New Jersey, U. S. A.

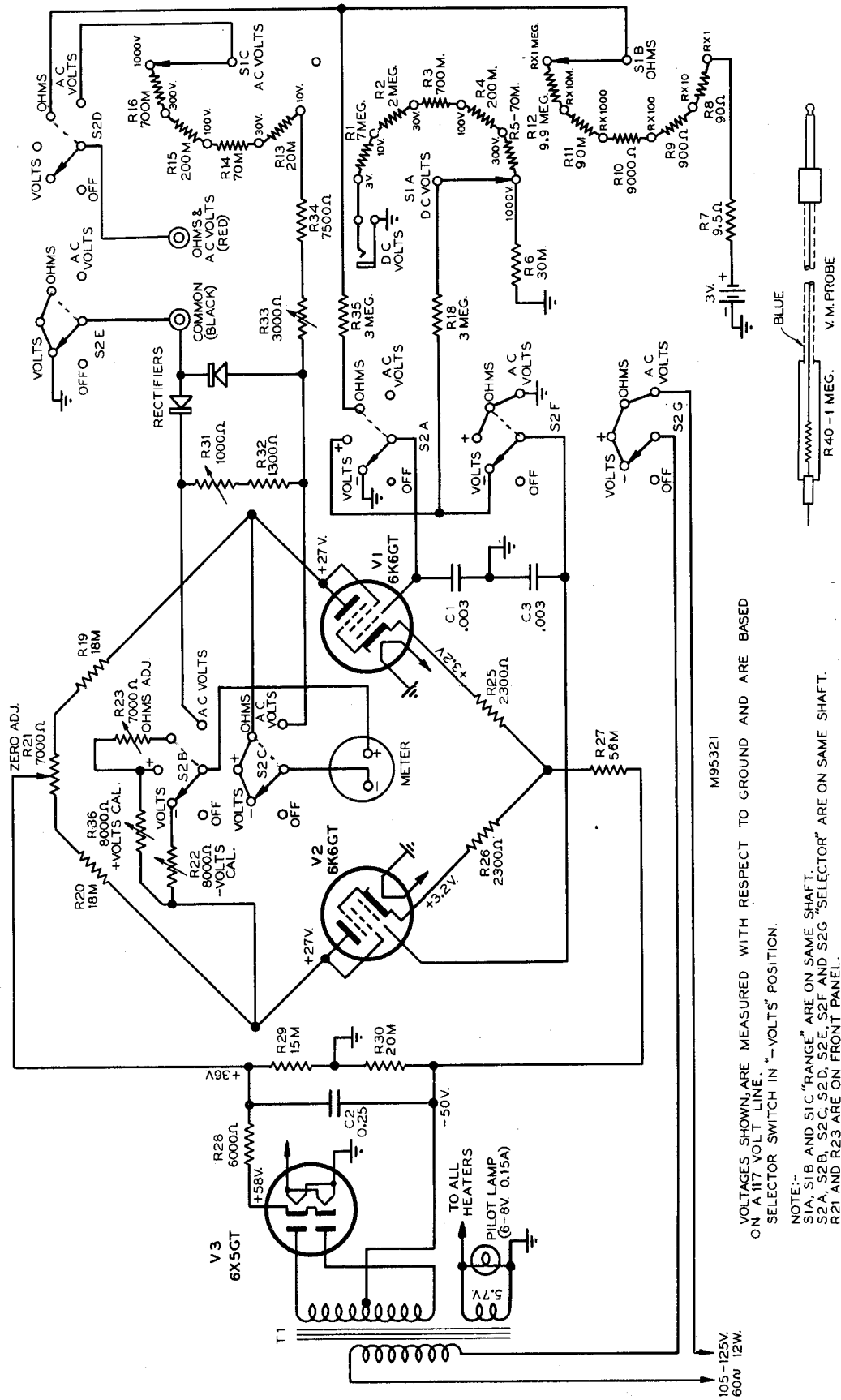

VOLTAGES SHOWN ARE MEASURED WITH RESPECT TO GROUND AND ARE BASED ON A 117 VOLT LINE.
 SELECTOR SWITCH IN "-VOLTS" POSITION.

NOTE: -
 S1A, S1B AND S1C "RANGE" ARE ON SAME SHAFT.
 S2A, S2B, S2C, S2D, S2E, S2F AND S2G "SELECTOR" ARE ON SAME SHAFT.
 R21 AND R23 ARE ON FRONT PANEL.

Figure 1—Schematic Circuit Diagram, Type No. 165-A, Code 943

JUNIOR VOLTOHMYST TYPE NO. 165-A

Specifications

D-C Electronic Voltmeter:

- 6 Ranges—0 to 3, 10, 30, 100, 300 and 1000 volts.
- Input Resistance—11,000,000 ohms constant for all ranges.
- Sensitivity—3 volt scale—3,666,666 ohms per volt.

A-C Voltmeter:

- 5 Ranges—0 to 10, 30, 100, 300 and 1000 volts.
- Sensitivity—1000 ohms per volt.

Electronic Ohmmeter:

- 6 Ranges measuring from 0.1 ohm to 1000 meg-ohms.

Meter:

- Movement Sensitivity—200 microamperes, d.c.
- Accuracy $\pm 2\%$ of full scale.

Tube Complement:

- 2—RCA—6K6-GT In push-pull electronic circuit
- 1—RCA—6X5-GT Rectifier

Circuit:

Push-pull electronic vacuum tube voltmeter with balanced two tube bridge circuit provides stable operation independent of line voltage fluctuations. No grid current and controlled inverse feedback produces accurate readings over all ranges. A.C. circuit using copper oxide rectifier is isolated from ground and line.

Cabinet:

Welded steel case. Crystalline gray finish.

Dimensions:

9½" high x 6-5/16" wide x 6½" deep.

Shipping Weight:

Approximately 14 lbs.

Power Supply:

105/125 volts, 50/60 cycles.

Power Consumption:

12 watts.

Equipment:

- 1—Cable—"Common" lead with clip.
- 1—Cable—"AC-Ohms" lead with probe.
- 1—Cable—"DC" shielded lead with probe.
- 2—1½ V. Batteries.

GENERAL DESCRIPTION

The RCA Junior VoltOhmyst, Type No. 165-A, is designed to measure DC and AC voltages and resistances over an extremely wide range. Outstanding features of the instrument are its ease of operation; high input resistance; foolproof DC voltmeter which is automatically protected against burn-out; "ZERO ADJ." and "OHMS ADJ." that do not have to be reset when changing ranges; and its "signal tracing"

type of test probe which permits dynamic voltage measurements in signal carrying circuits without interfering with the action of the circuit.

The Junior Volt-Ohmyst will measure DC voltages which are positive or negative with respect to ground without switching leads. It will not interfere with the operation of any circuit or element across which it may be connected. It is not necessary to reset the zero adjustment when changing voltage ranges and all voltage measurements, regardless of polarity, can be made with the common lead connected to the chassis or ground simply by turning the polarity reversing switch.

During AC voltage measurements, with the "SELECTOR" in AC position the instrument is completely isolated from the line, and all AC voltages up to 1,000 volts can be measured. To secure complete isolation from the line, a rugged copper-oxide rectifier unit is used. The instrument need not be plugged into the line for AC measurements. The input circuit to the AC Voltmeter is polarized so that the meter is protected should DC voltages be accidentally measured with the AC probe, while the "SELECTOR" switch is in the "AC VOLTS" position and the "COMMON" lead connected to chassis ground. It is necessary to exercise the usual precautions as to proper selection of AC meter ranges. Since the AC voltmeter employs a copper oxide rectifier instead of the electronic circuit of the DC meter, it is possible to damage the meter movement or the rectifier by overload due to incorrect AC range selection.

CIRCUIT DESCRIPTION

The Junior VoltOhmyst uses a push-pull DC electronic vacuum tube voltmeter of new design. Its schematic circuit is given in Figure 1. Unlike the conventional balanced voltmeter, the two type 6K6GT tubes are linked by means of a common high resistance R-27. Because of this coupling any change in the input voltage to the grid of V-1 changes the cathode bias of V-2 and as a result the change in the plate current of V-1 is accompanied by a simultaneous change in the plate current of V-2 in the opposite direction. The differential voltage thus developed across the load resistors R-19 and R-20 is applied to the meter which is calibrated in terms of the voltage applied to the grid of V-1, and in terms of resistance when the instrument is being used as an Ohmmeter.

In addition to the push-pull action, a high degree of self regulation is obtained as a direct result of the high value of coupling resistance R-27. This is due to the regulating effect secured through the use of self bias, but because R-27 is approximately 100 times as large as the value of cathode resistance which it is possible to use in conventional circuits, the self regulating action is correspondingly increased. At the same time the excessive loss of sensitivity normally experienced when using such a high cathode resistance is eliminated in the VoltOhmyst because of the balanced nature of the circuit. A controlled amount of inverse feedback to obtain independence of tube characteristics is secured by means of the two resistors R-25 and R-26.

A principal factor limiting the maximum input resistance of DC vacuum tube voltmeters has been the problem of reducing grid current and the so-called "contact potential" error to a low value. In the Junior VoltOhmyst, this problem has been solved successfully by the choice of a suitable tube type, the use of a very high cathode resistance, and by operation at a low plate voltage.

A one megohm resistor is built into the ungrounded but shielded d.c. voltmeter probe which effectively makes it a "signal tracing" type of probe and makes possible dynamic voltage measurements in signal carrying circuits.

The Ohmmeter circuit places the unknown resistance in series with a 3 volt battery and one of six standard multiplying resistors. The electronic d.c. voltmeter is then used to measure the voltage drop across the unknown resistor. The standard resistors range in value from 10 ohms to 10 megohms, which provide multiplying factors from Rx1 to Rx1,000,000.

As is to be expected from a consideration of the circuit, the Junior VoltOhmyst is exceedingly stable in operation, requires no readjustment of the zero adjusters when changing ranges, and is essentially independent of changes in line voltage and tube characteristics.

INITIAL ADJUSTMENT

Plug the red lead into the pin jack marked "OHMS-AC," plug the black lead into the pin jack marked "COMMON," and plug the blue lead into the jack marked "DC VOLTS." Before turning the instrument on, check the zero setting of the meter pointer, and if necessary turn the meter centering screw until the meter pointer reads exactly zero.

Plug the power cord into the 110 volt AC supply, turn the selector switch from the "OFF" position to "+ VOLTS" and allow several minutes for the instrument to warm up.

Adjust the "ZERO ADJ." control, until the meter pointer reads zero.

Turn the "SELECTOR" switch to the "OHMS" position. The pointer will now deflect to approximately full scale. Then turn the "OHMS ADJ." control so that the pointer reads exactly to the last line of the "OHMS" scale.

The instrument is now ready for use to measure resistance, AC voltage, or DC voltage.

DC VOLTAGE MEASUREMENTS

Connect the ground lead (black lead with alligator clip on the end) to the ground terminal of the apparatus on which voltage measurements are to be made, or to the grounded side of the voltage which is to be measured.

Set the "RANGE" switch to the proper range for the voltage which is to be measured. Set the "SELECTOR" switch to "- VOLTS" or "+ VOLTS" according to the polarity of the voltage to be measured.

Use the blue voltmeter lead and place its probe tip in contact with the point at which the DC voltage is

to be measured, being careful to keep the fingers well away from the probe tip in order to avoid stray pick-up.

All DC voltages should be read on the middle scales marked DC "VOLTS."

Greatest accuracy is always secured when a meter deflection as close to full scale as possible is obtained. Therefore, it is always advisable to use whatever setting of the "RANGE" switch will produce this deflection.

Never attempt to use a reading which may be slightly beyond the last calibration mark on the meter scale because such readings are likely to be very inaccurate.

The ground lead of the Junior VoltOhmyst should always be connected to the grounded side of the apparatus being measured. When a voltage is to be measured, both sides of which are above ground potential, readings should be taken between ground and each of the two sides. The difference between these two readings will then be the voltage existing between the two points in question.

AC VOLTAGE MEASUREMENTS

AC voltages should always be measured by using the red lead and the black lead. The "SELECTOR" switch should be turned to the "AC VOLTS" position which isolates the meter and the red and black leads from all other circuits. Consequently it is immaterial whether or not the instrument is plugged into the power line.

Caution: Be sure the "SELECTOR" switch is set at "AC VOLTS," for damage to the resistor network of the instrument may result if the red and black leads are connected across a voltage source when the "SELECTOR" is set at "OHMS."

The "RANGE" switch should always be turned to a higher scale than the voltage to be measured before the test leads are connected to this voltage. If necessary the "RANGE" switch can then be rotated to a lower scale. This procedure will protect the meter from severe overload which might damage the instrument when measuring AC voltage.

For greatest accuracy in AC measurements, use a setting of the "RANGE" switch that will produce a deflection as close to full scale as possible.

CAUTION! HIGH VOLTAGES ARE DANGEROUS! Use the utmost care to avoid accidental contact with, or even close proximity to high voltage points. Use one hand only! Keep the fingers and all other parts of the body as far away as conveniently possible from any high potential point. If at all possible when making either AC or DC high voltage measurements attach the test leads to the circuit to be measured with the power turned off. After completing the measurement, turn the power off again and make sure any condensers in the circuit are discharged before removing the test leads.

RESISTANCE MEASUREMENTS

Before attempting any resistance measurements care should be taken to see that the resistance being meas-

ured is not connected across any source of voltage and also that no voltage exists between either terminal of the resistance and ground.

The red and black leads should be used for all resistance measurements. The "SELECTOR" switch should be rotated to the "OHMS" position. The "RANGE" switch should be rotated until a reading as near mid-scale deflection as possible is secured. The resistance in ohms is then obtained by multiplying the reading shown on the "OHMS" scale by the factor indicated on the "RANGE" switch.

It is recommended that the "Rx1" position of the "RANGE" switch be used only for resistance measurements below 20 ohms.

To cancel the lead resistance error when making measurements below 2 ohms short the test leads together and reset the "ZERO ADJ." control so that the pointer reads exactly zero. This new setting will be slightly different from the original setting because of the resistance of the test leads. Then make the regular resistance check. When the measurement has been completed the "ZERO ADJ." control should be reset in accordance with the procedure given above under subject heading "INITIAL ADJUSTMENT."

When measuring high resistances the fingers should be kept away from the red lead and its probe. This will eliminate possible error due to leakage and stray pickup. This is especially important on the "Rx10,000" and "Rx1 MEG." ranges.

Caution: Since the instrument applies a voltage up to three volts across the resistance being measured, it is possible to burn out low filament voltage tubes in attempting a continuity or resistance test across their filaments. The approximate voltages applied by the instrument across resistances being measured are as follows (regardless of position of range switch): One-fourth scale meter reading—0.75 V.; half scale meter reading—1.5 V.; three-fourths scale meter reading—2.25 V.; full scale meter reading—3.0 V.

RESISTANCE MEASUREMENTS ABOVE 1,000 MEGOHMS

The voltmeter section of the Junior VoltOhmyst can be used to measure resistances higher than those covered on the "Rx1 MEG." range. This application is especially useful for the measurement of the leakage resistance of paper and mica condensers which, for the smaller capacities, is usually above 1,000 megohms.

An external voltage supply is required as shown in Figure 2. This voltage may range in value from approximately 20 to 500 volts. The higher the voltage

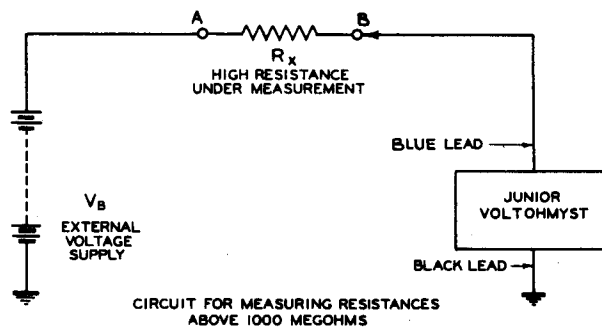

Figure 2

the higher the value of resistance which it is possible to measure. Make connections as shown in Figure 2 and note the DC voltage readings on the Junior VoltOhmyst at "A" and at "B," using the most convenient DC range for each measurement. If the voltage at "B" is too small to be accurately readable, increase the value of the external voltage supply until the voltage at "B" can be conveniently measured. The unknown resistance can then be found from the following formula.

$$\text{Unknown Resistance} = 11 \times \frac{\text{Reading at "A" minus reading at "B"}}{\text{Reading at "B"}}$$

(In Megohms)

Example:

External voltage supply, reading at "A" (on 1,000 V. range of Junior VoltOhmyst) = 500.

Reading at "B" (on 3 V. range of Junior VoltOhmyst) = 2.

$$\text{Unknown Resistance} = 11 \times \frac{500 - 2}{2} = 2,739 \text{ Megohms}$$

MAINTENANCE

Figure 1 shows the schematic circuit diagram of the Junior VoltOhmyst. The voltages shown on this diagram are actual operating voltages when the instrument is operated on a line voltage of 117 volts. Another Junior VoltOhmyst can be used for checking these voltages.

DC CALIBRATION ADJUSTMENT: The Junior VoltOhmyst, Type No. 165-A, is provided with two calibration adjustments R-22 and R-36 (Figure 3) which are originally set at the factory to compensate for variations in meter sensitivity and tube characteristics. These adjustments ordinarily do not require changing except when tubes are replaced. If readjustment is necessary, use a known source of DC voltage of exactly 3 volts and proceed as follows:

1. Check the mechanical zero of the meter.
2. Turn on the power, allow the instrument to warm up for about 30 minutes. Set the "SELECTOR" switch to position marked "+

VOLTS," turn the "RANGE" switch to position marked "3V.DC," and turn the "ZERO ADJ." until the meter reads exactly zero.

3. Connect the Junior VoltOhmyst across the source of exactly 3 volts. The accuracy of the calibration of the instrument depends on the accuracy of the standard 3 volt source, which should be carefully checked with a voltmeter known to be accurate; or use the voltage drop across an accurate 1,000 ohm resistor with exactly 3 m. a. flowing through it.
4. Adjust R-36 so that the meter reads exactly 3 volts.
5. Turn the "SELECTOR" switch to "—VOLTS," reverse the leads for proper polarity and adjust R-22 so that meter reads exactly 3 volts.
6. After the adjustment is completed, the two 6K6GT tubes should not be interchanged since this may have a slight effect on the accuracy of calibration.

AC CALIBRATION ADJUSTMENT: Two internal adjustments, R-31 and R-33 (Figure 3), which are set at the factory, are provided to compensate for variation in both rectifier and meter characteristics, and to insure the greatest possible accuracy of the AC ranges. These adjustments should not be changed unless one or more of the components in the AC voltmeter section of the circuit is replaced. If necessary to readjust, proceed as follows:

1. Check the mechanical zero of the meter.
2. Set the "SELECTOR" switch to position marked "AC VOLTS" and the "RANGE" switch to position marked "100 V." Apply an AC voltage of exactly 100 volts to the test leads. This voltage should be of good wave form and should be measured by an instrument which is known to be accurate. The 60 cycle power line is a convenient source of such voltage.
3. Adjust R-31 so that the meter reads exactly full scale (100 volts).
4. Remove the 100 volts and apply a known voltage of 10 volts to the test leads. Set the "RANGE" switch to 10 volts.
5. Adjust R-33 so that the meter reads exactly full scale (10 volts).
6. The procedure for adjusting R-31 and R-33 should be repeated until no further change is required. Usually it will not be necessary to go over these adjustments more than two times.

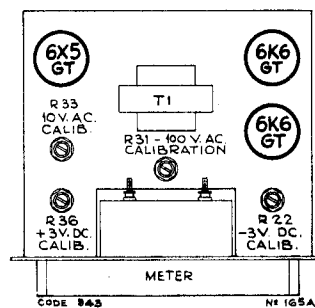

Figure 3—Tube and Adjustment Layout

TUBES: The Junior VoltOhmyst employs two type 6K6GT and one type 6X5GT RCA preferred type tubes. Because of the low operating voltages the tube life will be unusually long. However, when replacement becomes necessary, care should be taken to see that the two type 6K6GT tubes are approximately balanced. If they are unbalanced, it will be impossible to bring the pointer to zero by means of the "ZERO ADJ." control. If this should happen, the tubes should be interchanged and the adjustment tried again. If it is still impossible to bring the pointer to zero, the tubes have different characteristics and each one should be matched with another tube in order to obtain a balanced pair. When the tubes are matched, it will be possible to bring the pointer to zero with the "ZERO ADJ." control. The unique circuit design of the Junior VoltOhmyst is such that grid current is reduced to a negligible value. However, when replacing tubes, it is advisable to check for grid current as occasionally a gassy tube will be found. The presence of gas is indicated by an appreciable change in the pointer position when the "RANGE" switch is changed from the 3 volt position to the 30 volt position while the "SELECTOR" switch is in the "+ VOLTS" position.

MAINTENANCE

METER NEEDLE OFF SCALE: If the meter needle drives violently off scale when no test is being made, the cause may be due to the meter circuit being grounded. Check circuit for grounds, being sure the grounded covers of the potentiometers (R-21, R-22, R-23, or R-36) are not making contact with any part of the circuit both inside and out.

If it becomes necessary to insulate the inside of a potentiometer cover, be careful not to disturb the adjustments of R-22 and R-36 or recalibration with a voltage standard will be necessary.

APPLICATIONS

OSCILLATOR STRENGTH: The DC voltage developed on the oscillator grid is always directly proportional to the strength of oscillation. This voltage can be measured very readily at the oscillator grid while the band switch is changed to the various bands and in each of its positions the main tuning condenser rotated from minimum to maximum capacity. This will give an indication of the strength of oscillation at all frequencies within the oscillator's range.

AVC VOLTAGE: The automatic volume control voltage developed by the incoming signal can be measured at a number of places in the receiver. This voltage first appears across the diode load resistor. It may also be measured along the AVC bus and at the grids of the r-f tubes being controlled. **THIS DC VOLTAGE MEASURED AT THE DIODE LOAD RESISTOR IS A VERY CONVENIENT OUTPUT INDICATION DURING RECEIVER ALIGNMENT.**

DC SUPPLY VOLTAGES: The power supply DC voltage can be measured at the rectifier filaments and in the filter circuit; plate voltages at the plates of the various tubes; screen voltages at the screen voltage dropping resistor; and cathode voltages at the tube cathodes.

BIAS CELL VOLTAGE: The Junior VoltOhmyst will accurately measure the voltage delivered by a bias cell. Most voltmeters are not capable of making this measurement and in many cases will damage the cell if it is attempted. This voltage should be measured across the cell.

AFC DISCRIMINATOR VOLTAGE: The discriminator voltage developed in radio receivers employing automatic frequency control can be measured directly at the discriminator and also at the grid of the oscillator control tube.

F.M. DISCRIMINATOR VOLTAGE: The DC voltage developed by the discriminator in a frequency modulation receiver can be measured right at the discriminator.

TELEVISION RECEIVER ADJUSTMENTS: The Junior VoltOhmyst is very useful for measuring the DC voltage developed in the picture channel of a television receiver across the second detector load resistor. This measurement is most useful when adjusting antenna orientation and position as well as when adjusting antenna matching sections.

GASSY TUBES: The effect of a gassy tube is to put a positive charge on its control grid instead of the negative charge which should normally be present. The Junior VoltOhmyst is ideal for measuring the voltage directly at the control grid of any tube in order to determine whether or not this effect is present. Much gas will cause the tube to cease operating normally and will usually produce considerable distortion. In the case of an audio amplifier tube where the control grid is connected directly to the contact arm of the volume control a small amount of gas can be present which will in time cause the volume control to become very noisy. This amount of

gas will not always produce a noticeable change in the operation of the radio receiver. Consequently if excessive difficulty is experienced with volume controls becoming noisy, in this type of circuit, this is one of the first things that should be checked.

AC VOLTAGES: The AC voltmeter within the Junior VoltOhmyst is extremely useful in measuring all AC voltages encountered in the average radio receiver. The measurements include line voltage, all voltages from power transformer secondaries, and audio voltage developed across the output transformer or voice coil as an indication of output during receiver alignment.

AC MEASUREMENTS WHEN DC IS ALSO PRESENT: A one microfarad (or larger) condenser can be used in series with either one of the test leads when using the AC voltmeter of the Junior VoltOhmyst. This will eliminate the DC component and permit the AC component to be measured. Such an arrangement makes possible use of the AC voltmeter to measure ripple voltage in a filter circuit and as an output meter for alignment purposes, as well as for many other applications.

MEASUREMENT OF RESISTORS, COILS, AND INSULATION RESISTANCE: The Junior VoltOhmyst because of the extremely wide range it covers when used as an Ohmmeter can be used to accurately measure the value of all resistors used in modern radio receivers. It can also be used to measure the DC resistance value of all coils such as r-f coils, oscillator coils, detector coils, i-f transformer coils, power transformer coils, audio transformer coils, filter reactors and others. Leakage through the insulation of condensers, coil windings, etc., can be measured directly using the Ohmmeter section, or if above 1,000 megohms, with the extended range circuit described above. If such condensers are used for coupling purposes between the plate of one tube and the grid of the following tube, leakage in the insulation will manifest itself as a positive voltage applied to the grid of the second tube. This voltage can be readily measured using the DC voltmeter portion of the Junior VoltOhmyst.

WARRANTY

This instrument is warranted to be free from defects in material and workmanship, in accordance with the terms of the guarantee card which accompanies each instrument.

BATTERY REPLACEMENT: Be certain the battery contacts are clean and tight so there will be no possibility of resistance at the connections. Use two Burgess No. 2 or two Eveready No. 950 Flashlight Cells, or equivalent.

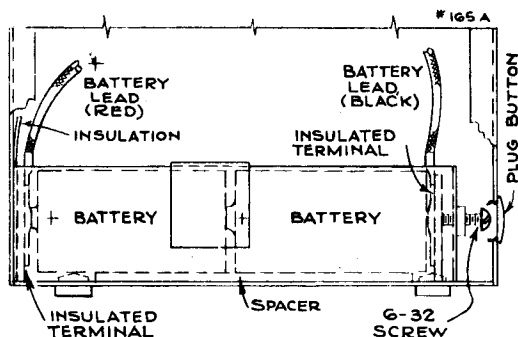

Figure 5—Battery Connections

BATTERY: Battery replacement is generally necessary, when the ohmmeter readings become unstable, especially on the "R x 1" scale. See Figure 4.

It is suggested that the batteries be tested occasionally to insure accuracy of ohmmeter readings as follows:

Set "RANGE" for "R x 1" scale and adjust "OHMS ADJ" until pointer reads full scale. Short circuit test leads (Red and Black) for about 10 seconds. Relieve short and immediately observe the full scale deflection. If shorting of the leads causes a substantial drop in the full scale reading, it is an indication that batteries are in a weakened condition.

If upon repeating the above test the drop is still noticeable it is advisable to replace the batteries.

CAUTION. Batteries should not be allowed to remain in test equipment after they have become exhausted or in equipment that is to remain idle for a long period of time as they deteriorate and may damage the instrument.

Replacement Parts

Insist on genuine factory-tested parts, which are readily identified and may be purchased from authorized dealers.

STOCK No.	DESCRIPTION	STOCK No.	DESCRIPTION
46990	Battery Connectors (1 pair)	33572	Resistor—1,300 ohms, ½ watt, 10% (R32)
43914	Cable—Lead with clip for "Common" connection (black)	43936	Resistor—2,300 ohms, 1 watt, 5% (R25, R26)
43913	Cable—Lead with probe for "AC-OHMS" connection (red)	35255	Resistor—6,000 ohms, ½ watt, 10% (R28)
43915	Cable—Shielded DC voltmeter lead with isolating probe (blue)	43937	Resistor—7,500 ohms, ½ watt, 10% (R34)
11622	Capacitor—0.003 mfd., 500 volts (C1, C3)	43932	Resistor—9,000 ohms, ½ watt, 1% matched pair (R10)
12484	Capacitor—0.25 mfd., 200 volts (C2)	35374	Resistor—15,000 ohms, ½ watt, 10% (R29)
43918	Control—1,000 ohms, AC shunt adjustment (R31)	30151	Resistor—18,000 ohms, 1 watt, 5% (R19, R20)
43922	Control—3,000 ohms, AC series adjustment (R33)	35370	Resistor—20,000 ohms, ½ watt, 1% matched pair (R13)
43917	Control—7,000 ohms, zero and ohms adjustment (R23, R21)	6240	Resistor—20,000 ohms, ½ watt, 10% (R30)
43916	Control—8,000 ohms, DC calibration adjustment (R22, R36)	43929	Resistor—30,000 ohms, ½ watt, 1% matched pair (R6)
14086	Cord—Power cord and plug	35519	Resistor—56,000 ohms, ½ watt, 10% (R27)
44091	Handle—Black leather, removable complete with fasteners	43928	Resistor—70,000 ohms, ½ watt, 1% matched pair (R5, R14)
43920	Jack—Black insulated, for "Common" banana plug connection	43933	Resistor—90,000 ohms, ½ watt, 1% matched pair (R11)
43921	Jack—Open circuit jack for DC electronic voltmeter cable plug	43927	Resistor—200,000 ohms, ½ watt, 1% matched pair (R4, R15)
43919	Jack—Red insulated, for "AC-OHMS" banana plug connection	43926	Resistor—700,000 ohms, ½ watt, 1% matched pair (R3)
47145	Jewel—Pilot lamp jewel and socket (Code 143)	43935	Resistor—700,000 ohms, 1 watt, 1% matched pair (R16)
34950	Knob—Bar knob	30652	Resistor—1 megohm, ½ watt (R40)
4323	Knob—Round knob	39988	Resistor—2 meg., ½ watt, 1% matched pair (R2)
31480	Lamp—Pilot lamp (Mazda type 47)	35358	Resistor—3 meg., ½ watt, 10% (R18, R35)
43923	Meter—200 microamperes	43925	Resistor—7 meg., 1 watt, 1% matched pair (R1)
46533	Probe—Probe only for "AC-OHMS" cable	43934	Resistor—9.9 meg., ½ watt, 1% matched pair (R12)
47182	Rectifier—Copper oxide, half wave	31251	Socket—Tube socket
43930	Resistor—9.5 ohms, ½ watt, 1% matched per pair (R7)	43938	Switch—Range switch, 3 section—3 pole—6 position (S1)
43931	Resistor—90 ohms, ½ watt, 1% matched pair (R8)	46989	Switch—Selector switch, 2 section—5 pole—5 position (S2)
19770	Resistor—900 ohms, ½ watt, 1% matched pair (R9)	43940	Transformer—117 volts, 50-60 cycle, power transformer (T1)

Replacement parts supplied are within Engineering Specification Tolerances.

44-11-2

Identification code and serial numbers are stamped on the bottom of the case.
Trademark "VoltOhmyst" Reg. U. S. Pat. Off. by RCA

Printed in U. S. A.